

# **MANUAL**

3/11/2009

---

---

## **INSTALLATION, OPERATION & MAINTENANCE**

**Commercial High Efficiency  
Heat Pipe Dehumidifier**

**Model BKP™ 250**

**Model BKP™ 250-AC**

**Model BKP™ 450**

**Model BKP™ 450-AC**

Heat Pipe Technology, Inc.  
4340 N.E. 49<sup>th</sup> Avenue, Gainesville, FL 32609  
Tel: (352) 367-0999  
Fax: (352) 367-1688  
<http://www.heatpipe.com>  
E-mail: [heatpipe@heatpipe.com](mailto:heatpipe@heatpipe.com)

## **INSTALLATION, OPERATION & MAINTENANCE**

---

### **1. GENERAL DESCRIPTION**

The BKP™s are commercial high efficiency dehumidifiers. They are radically different from other dehumidifiers because of the proprietary heat pipe used to exchange heat between the warm intake air and the cold air discharge from the evaporator. This process pre cools the incoming air and allows more moisture to be condensed for less energy spent. The heat pipes are passive devices that use no energy.

The BKP™ standard unit comes pre-charged with refrigerant. The BKP™ AC model is shipped in two sections which must be piped together, evacuated and then charged as a unit.

The BKP™ AC models, which are equipped with outdoor remote condensers, will also work as an air condition system to reject heat to the outdoors.

The BKP™ comes with a dehumidistat and a thermostat (AC models) for the unit with outside remote condenser. Condensate water is removed by gravity drain. The unit comes with an intake and supply air duct flanges. Pleated 2 in. air filters are standard and can be accessed through a separate cover from either side of the unit.

### **2. INSPECTION**

All HPT products are carefully tested and inspected prior to shipment. Each unit is in good working condition when packaged. If the package is damaged in any way, check the contents immediately; note damage on shippers Bill of Lading and have him/her sign your statement to insure prompt claim processing. Notify the carrier immediately of the damage so he can come out and inspect the product and packaging. The carrier alone is responsible for handling and settling your claim.

HPT will cooperate in assessing damage if unit is returned to the factory prepaid.

Unpack the unit. The following will be included: BKP™ dehumidifier, dehumidistat, thermostat (for the unit with outside remote condenser), user's manual and warranty card.

### **3. INSTALLATION**

The BKP™ can be placed as a stand-alone unit in an environment such as above the ceiling or in a mechanical room. The BKP™ is designed to operate in conditioned space with temperatures ranging from 60°F to 95°F. Special factory options may be ordered for operation above or below these limits.

#### **3.1 DUCTING**

The BKP™ can be used with suitable metal or fiberglass ducts using approved methods. The ducts must be sized appropriately for the airflow listed. A good quality air filter of equal or larger size may be installed in the inlet register and located for ease of maintenance. **The duct must not add more than 0.5" E.S.P. inclusive of both supply and return ducts.**

When the BKP™ is used to handle outside fresh air, a branch of the intake can be ducted to outside. The BKP™ is designed to handle as much as 25% fresh air and will remove most of the moisture from the air before admitting it to the building. Additionally, the supply dry air can be ducted or injected to the supply duct of the main air handler for a building providing the back pressure from the main air handler does not reduce the air flow through the BKP™. the blower of the main air handler may also need to be interlocked to the BKP™ so that the blower runs when the BKP™ runs to distribute the air. A back draft damper will also be needed for the BKP™ to prevent the main AC from blowing back through the BKP™ when it is not running.

### 3.2 Condensate Drain

The BKP™s are supplied with a condensate gravity drain outlet. For the gravity drain, the pipe must have a downward slope for the entire distance to the outside. If installed above the ceiling, the pipe must be supported every 3 or 4 feet to prevent sagging. If the line has any level runs or dips, it will not drain properly. Ensure that the drain line has a trap to prevent outdoor air from being aspirated into the BKP™ and prevent draining. If the piping goes underground and back up outside, this is considered an adequate trap. **Do not double trap.** This may prevent the condensate from draining due to the air pocket between two traps. Due to the high static pressure across our dehumidifier coils, a 2 inch minimum trap is required.

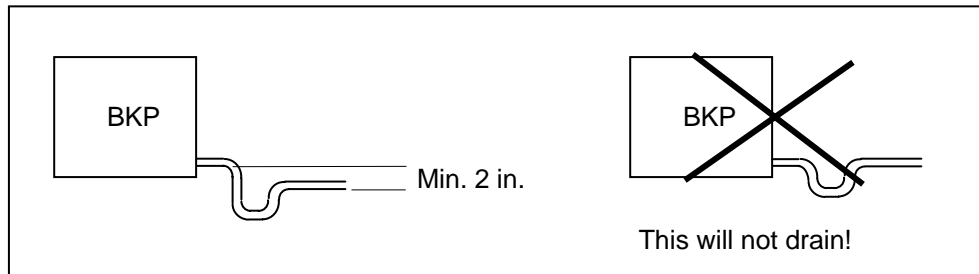

Fig 3.2 Condensate trap

For installation above the ceiling or above the ground floor, it is recommended that the BKP™ be installed over a separate drain pan, which is piped to a separate drain point.

### 3.3 Units with a Remote Condenser

Install the remote condenser in an outdoor, well ventilated and preferably well-shaded area. Ensure that the hot air discharge is not obstructed. Install on a concrete pad or as required by local codes.

#### For Remote Condenser Unit:

**CAUTION:** Coil is pressurized with a few PSI of nitrogen. Punch hole in copper to relieve pressure before cutting off end to connect line.

### 3.4 Condenser Piping

The BKP™ with remote condenser is shipped with a holding charge of dry nitrogen. Release the pressure before un-sweating the caps from the tubing connection. Connect the BKP™ to the remote condenser using refrigerant tubing of the sizes listed in Table BKP01. The tubing needs not be insulated except in exposed areas where the hot gas line might cause harmful burn. Solder the connections with suitable silver brazing alloy and leak check. An additional Refrigeration charge will have to be added to the nameplate charge depending on the liquid line size and length. See section 4. Charging the BKP™

Table BKP01

Model	250-AC	450-AC
Liquid	3/8	3/8
Vapor	1/2	1/2

Note:

This BKP-AC remote line sizing applies to most applications, up to 50 feet horizontal, and within 10 feet vertical (ACR OD line sizes).

### 3.41 Long Line Sets (50 ft or Longer)

For line sets where there are no vertical sections greater than 10 ft. and for lengths up to 150 ft. increase the vapor line one size larger but leave the liquid line size as is. Also add 4 extra ounces of refrigerant oil (3GS or Equivalent) to the system for every 50 ft. over 50 ft.

### 3.42 Vertical Line Sets

When the BKP™ -AC remote condenser is installed either on a roof above the BKP™ Unit, or on the ground where the BKP™ unit is on an upper floor or attic, special consideration needs to be taken to insure that Oil will return to the compressor. Unlike a split system air conditioner, the compressor is in the indoor unit.

If the remote condenser is above the indoor unit, special P-Traps need to be installed in the vapor line at the bottom of the vertical section and every 10 ft. above that. Small particles of oil that circulate with the Vapor will accumulate in the traps until they are large enough to be carried up the pipe by the velocity of the refrigerant. Vertical sections of tubing should not be enlarged beyond that specified in table BKP01. Pre-manufactured traps are available at the air conditioning supply houses or traps can be made up using long radius ells of the same size as the tubing.

If the remote condenser is below the indoor unit no special changes are necessary. The oil will travel down hill with the vapor to the condenser and return with the liquid refrigerant to the indoor unit.

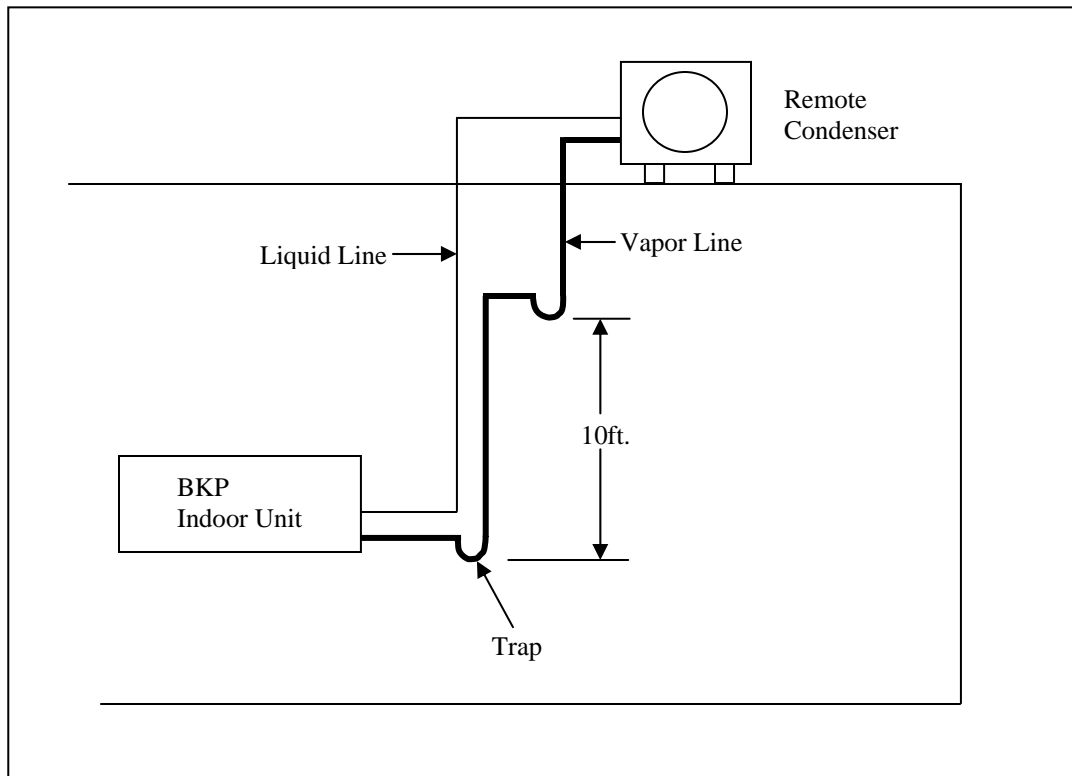

Fig 3.42 P-Traps must be added to vertical lines over 10 ft. where remote condenser is higher than the indoor unit.

## 4. ELECTRICAL WIRING

**CAUTION: Units with three phase compressors can be damaged by running backward.** Verify correct compressor rotation by observing refrigerant pressure gauges at startup. Little or no gauge movement indicates reverse rotation. Reverse any two leads in the power junction box.

**Note:** Fan blower motor is single phase and not affected by lead connections.

### 4.1 Power Supply

Use properly sized wire. Install and connect unit in accordance with local codes. Unit must be grounded. Size separate circuits to the BKP™ and to the Remote Condenser.

### 4.2 24 VAC Control Wiring

#### Units Without Remote Condenser

A dehumidistat is supplied with the unit. It should be placed in the conditioned space away from heat sources, entrance doors or any sources of humid air. It is recommended to place the dehumidistat at a location where it could sense the average relative humidity of the space.

The dehumidistat is of the 24 V type and should be wired with T-stat 18 gauge, low voltage wire. (See wiring diagram in unit control panel.)

#### Units with Remote Condensers

For operation of units with a remote condenser, both temperature and humidity are controlled. A 24V thermostat and a 24V dehumidistat are supplied with the BKP AC™. Wire the controls with Thermostat 18 gauge low voltage wiring in accordance with the wiring diagrams.

**NOTE:** The operation of the remote condenser is by an internal pressure switch. No control wiring is needed to the outdoor condenser.

## 5. Charging The BKP

The BKP™ is charged with refrigerant 22. The charge amount is listed on the nameplate. It is important to have exactly the right charge in the unit or damage to the compressor or refrigerant components may occur. Due to the wide range of operation of the BKP™ it is highly recommended that the charge be weighed in to the ounce.

### 5.1 Standard Unit

Standard units (Non AC Models) are factory charged and ready to run after installation and wiring. If the charge is in question, first, recover the refrigerant in the system and weigh in the proper charge. If it is determined that the unit has a refrigerant leak, the leak must be repaired. Even though the unit appears to operate, as the refrigerant level drops the compressor will over heat and be damaged before the condition is recognized. Repair the leak and replace the liquid filter dryer. Evacuate the system using a Micron Gauge down to 400 microns. Valve off the vacuum pump and insure the vacuum does not rise above 700 microns. Then weigh in the charge using a scale accurate to 1 ounce.

### 5.2 AC Unit

The BKP™ AC model is shipped in two sections which must be piped together, evacuated and then charged as a unit. Evacuate the refrigerant system to 400 microns or below. Valve off the vacuum pump and insure the micron level does not increase above 700 microns. For BKP™ -AC units the system must be evacuated from all three ports. This is due to the check valves used in the remote condenser. A 1/4 in. flair Tee and an extra refrigeration hose can be used to double up the discharge hose. **Remove the extra**

**hose from the remote condenser tap after charging and before running the unit.** Weigh in the refrigerant charge using the suction and discharge ports. The proper charge of refrigerant 22 for the unit and the remote condenser can be found on the nameplate. It is important to have the proper charge of refrigerant. The preferred method of charging is to weigh in the charge from the nameplate with a scale, which can be accurate to plus or minus one ounce. Additional refrigerant needs to be added for the length of the line set. The liquid line (the smaller line) is full of liquid in both the heating and cooling modes of operation. Measure the length of the line set **one-way** and add to the charge as follows:

- 3/8 in liquid line - add 0.8 oz per foot
- 1/2 in liquid line - add 1.5 oz per foot
- 5/8 in liquid line - add 2.5 oz per foot

### 5.3 ALTERNATE CHARGING METHOD

**NOTE: This method will only work if enough load can be maintained on the BKP™ that the suction pressure does not fall below about 65 PSIG while charging.** It will be necessary to fabricate a cover out of cardboard the same size as the front cover (use the cover as a template) in which a small flap can be cut for observing the sight glass. **Do not run the unit without a cover in place.** With the BKP™ turned off, charge the unit with liquid until the unit can be run without shutting down on low pressure. Start the unit in the heating mode and charge vapor into the low side port until the sight glass almost clears. Run the unit for 15 minutes and then slowly add vapor until the sight glass just clears.

## 6. OPERATION

The dehumidistat controls the operation of the dehumidifier.

### Units Without Remote Condenser

Set the dehumidistat at the desired level, the dehumidifier will run and remove humidity until the set humidity is reached, at which time the dehumidifier will shut off. For normal operation, a range from 50% to 60% will provide the best comfort. Settings below 50% will make the unit run longer and less economical. Settings above 60%, which may be required in certain situations, will be more economical, but may not provide adequate human comfort.

### Units with Remote Condensers

The BKP™-AC with remote condenser is designed to control space temperature as well as humidity. Therefore, they are controlled by both a dehumidistat and a thermostat. This design allows the BKP™-AC to switch from normal operation to remote condenser operation automatically when extra cooling is needed in the space. In the remote condenser mode, the BKP™-ACs dehumidify and provide additional cooling to the space at the same time.

The thermostat should be set 2 to 3°F below the setting on the building thermostat so that the BKP™ operation will not interfere with the operation of the building A/C. The latter will continue to cycle on and off to maintain the building temperature. When the building A/C cycles off, with the lower thermostat setting, the BKP™ continues to run in the thermostat cooling mode until the temperature drops to its onset point. The BKP™ then shifts to its normal mode, discharging dry warm air.

When the temperature rises to its thermostat set point, the BKP™ again shifts to the additional cooling mode. Therefore, it will cycle back and forth to maintain the inside temperature at its set point and the building A/C will not cycle on unless the temperature has risen up to the building's higher thermostat set point. In this manner, the building A/C cycles on only when the cooling by the BKP™ is not sufficient. When the relative humidity is down to the desired setting, the BKP™ -AC will shut off and the building will be back to its normal A/C operation.

During the wintertime when the space must be heated, the BKP™'s thermostat should be set 2 to 3 degrees above the main heating thermostat. This will use the BKP™'s normal dehumidifying operation mode to provide additional heating to supplement the building's heating system while the BKP™ runs. It will continue in this mode until its dehumidistat is satisfied.

**NOTE: The BKP™ is not designed to cool when the outdoor temperature is below 50°F. Refrigerant Migration will occur and the unit will shut down on low pressure.**

## **7. MAINTENANCE**

It is essential that the air filter on the inlet of the unit be kept clean in order to prevent excessive power consumption and possible damage to the unit. Check the filters routinely to determine the frequency of replacement.

Keep the outdoor remote condenser free of leaves and grass clippings, which may impede air, flow.

Check condensate drain regularly to ensure that the condensate is draining properly. If installed with an auxiliary drain pan under the unit, check that it is dry.

It is recommended that the BKP™ be serviced annually by an authorized HPT certified technician to provide maximum efficiency and insure long life equipment.

## **8. SERVICE DIAGNOSIS**

The BKP™ is equipped with safety controls, which will shut down the unit if a problem occurs. The BKP™ will remain locked out until it is reset by either raising and then lowering the dehumidistat setting or by turning the power to the BKP™ off and then back on.

### **If the unit locks out:**

1. Check the air filter in the inlet of the unit. A dirty air filter will cause an increase in power consumption and in the long run may cause damage to the unit.
2. Check the remote condenser. If the air is blocked or the hot air discharge is not free to dissipate, a high discharge pressure will result and may cause damage to the BKP™.
3. Check the power supply to the remote condenser. It will be on a separate breaker and if tripped will cause the BKP™ to shut down.
4. Check refrigerant charge as described above.

### **To reset the BKP™**

Reset the BKP™ by either raising and then lowering the dehumidistat setting or by turning the power to the BKP™ off and then back on. Allow 5 minutes for the BKP™ to restart. If the unit locks out again after restart, thoroughly check the operation of the BKP™ to determine the cause of the shutdown and correct the problem. See troubleshooting section below.

## 9. Sequence of Operation for Standard Unit

The BKP™ is controlled, on or off, by a dehumidistat which senses the relative humidity of the space. The BKP™ units have a remote mounted dehumidistat and are designed to be used with a duct system having a total external static of 0.5 in H<sub>2</sub>O or less.

On a call for dehumidification the contact in the dehumidistat is made sending control power through the safety shutdown switches, through the lockout relay and to the blower relay. Control power is also sent through a recycle time delay to the compressor contactor.

The safety shutdowns consist of a high and low refrigerant pressure cutout. If either of these cut-outs open, the current path from the dehumidistat to the contactor is shifted through the coil of the lock-out relay. The normally closed contact in the lockout relay opens and the normally open contact closes, essentially shorting across the coil of the compressor contactor and providing full control voltage to the lockout relay coil.

The contactor will remain off as long as the lockout relay receives voltage from the dehumidistat. Turning the dehumidistat up and then back down, mechanically opens the contact in the dehumidistat, dropping the power from the lockout relay.

After reset, voltage can now go through the normally closed contact of the lockout relay to the compressor contactor and blower relay, provided the safety shutdown has cleared. Control power to the contactor will be resumed through the off-cycle time delay when the machine has been off for the selected number of minutes (factory set to 5 minutes for single phase units 3 minutes for 3 phase units).

A hot gas bypass valve is installed to prevent coil freeze-up. The hot gas bypass starts to open if the suction pressure drops below 60 PSIG for any reason, and bypasses hot gas directly into the evaporator to prevent the coil temperature from dropping below freezing.

The refrigerant system is a R-22 (Chlorodifluoromethane) system consisting of a compressor, condenser coil, sight glass, filter dryer, Thermal expansion valve, and an evaporator with dehumidifier heat pipes. The coil section contains both the evaporator and condenser coils. The airflow enters through the precool heat pipe then through the evaporator then the reheat heat pipe and the condenser.

### 9.1 Remote Condenser Units

The BKP-AC™ series operates similar to the standard unit except that it has a liquid receiver and employs a separate outdoor condenser. Since the standard unit discharges air through the condenser coil, the discharge air temperature will always be warmer than the inlet air and can reach temperatures above 100°F. The BKP-AC™ unit, on the other hand has an outdoor condenser as well an indoor condenser.

These units use a separate remote mounted thermostat along with the dehumidistat to control the BKP-AC™. The dehumidistat operates the unit on and off as described above. The thermostat controls a reversing valve that diverts the refrigerant flow between the indoor and outdoor condensers. When the temperature is below the set point, the valve sends the refrigerant through the indoor condenser. This has the effect of warming the space temperature. When the temperature is above the set point the valve sends the refrigerant through the outdoor condenser. The BKP-AC™ then acts as an air conditioner, bringing the space temperature back down. The BKP-AC™ will switch back and forth between indoor and outdoor condenser until the dehumidistat is satisfied.

The thermostat gets its control power from the red wire going to the dehumidistat. On a drop in temperature, the thermostat contact sends control power directly to the reversing valve coil.

The outdoor condenser is powered from a separate power supply. No control voltage wiring is connected. A head pressure switch inside the outdoor condenser controls the fan. The fan comes on when the pressure in the outdoor coil reaches 240 psig and shuts off when it drops below 190 psig.

The refrigerant flows from the compressor to the reversing valve inlet. In the de-energized state the flow is sent to the indoor condenser. The line going to the outdoor condenser is internally connected to the reversing valve's center suction port, which is connected to the suction line coming out of the evaporator by a 3/16" tube. This tube has a check valve installed in it. Any refrigerant in the outdoor condenser will be pulled back through this 3/16" tube as the compressor runs. A check valve in the leaving liquid line of the outdoor condenser prevents refrigerant from being pulled backward through the condenser coils.

When the reversing valve shifts to the outdoor condenser the indoor condenser is connected to the suction by the 3/16" line. The indoor coil also has a check valve in the liquid line out.

The 3/16" line to the suction header provides a smoother transition when shifting. A hissing sound for 10 to 20 seconds is normal while the machine equalizes after shifting.

The BKP-AC™ also has a liquid receiver in the common liquid line.

If the BKP-AC™ is installed in an application where it may need to run in the winter when outdoor temperatures will be below freezing, special provisions need to be made in the installation. An outdoor thermostat must be installed to prevent the BKP-AC™ from shifting to the outdoor mode when temperatures are below 50°F. If the unit is allowed to shift to the outdoor condenser when the temperature is below that of the evaporator temperature, the compressor will not be able to pull the refrigerant back when it shifts to the indoor coil and the unit will shut down on low pressure. A check valve in the liquid line and in the small suction return line prevent refrigerant from migrating to the outdoor coil during cold weather, while the unit operates in the Heating Mode.

## 9.2 OPTIONAL EQUIPMENT

### 9.21 Phase Loss Monitor for Three Phase Units

Units with a Phase loss monitor are provided with fuses which feed the phase loss monitor and the control transformer. The monitor has an adjustable setting for operating voltage which determines the trip settings. **This voltage must be set at startup to the measured line voltage.** This monitor samples the voltage between all three phases and closes a set of normally open contacts when the voltage and phase rotation is correct. A red LED lights up to indicate the contact is closed. The contact will open if line voltage on any phase drops by 10% of the adjusted line voltage setting or an unbalance of 4% occurs between phases. The contact will open to drop the 24 V control power to the control system.

### 9.22 Cooling Priority Relay

Units with a cooling priority relay will energize the BKP™ in the cooling mode on a call for cooling from the thermostat even if the dehumidistat is satisfied. Control voltage from the thermostat to the reversing valve is used to energize the cooling relay. Normally open contacts 2 and 4 close to supply control power directly from the transformer to the yellow wire coming from the dehumidistat. When the thermostat is satisfied, the BKP™ will shut down again.

## 10. SPECIFICATIONS

### BKP™ 250, 450

<b>Models</b>	<b>250</b>	<b>450</b>
Capacity (lbs/day) at 80°F & 60% RH (AHAM)	250	440
Capacity (lbs/day) at 80°F & 50% RH (ASHRAE)	195	343
Air Flow Rate (cfm)	600	1000
Operating Range		
Dimensions (WxHxD) (in.)	45 x 22 x 22	45 x 22 x 34
Net Weight (lbs)	200	290
Filter Size (WxHxD) (in.)	16 x 20 x 2	2 - 16 x 16 x 2
<b>Electrical (60 Hz)*</b>		
Voltage/Phase	208/230 V/1 ph**	208/230 V/1 ph**
Max. Fuse or HACR Circuit Breaker (A)	30	50
Min. Circuit Ampacity (A)	19	29
Normal Operating Power (W)	2500 W	3500 W
Compressor	Scroll	Scroll
Blower Motor Power (hp)	1/4	1/2
Condensate Pumps	Optional	Optional

### BKP™ 250-AC, 450-AC

<b>Models (Outdoor Unit)</b>	<b>250-AC</b>	<b>450-AC</b>
Dimensions (WxHxD) (in.)	24 x 25 x 20	24 x 25 x 30
Net Weight (lbs)	65	95
Air Flow Rate (cfm)	800	1800
<b>Electrical (60 Hz)*</b>		
Voltage/Phase	208/230 V/1 ph	208/230 V/1 ph
Fan Motor	1/4	1/4
Normal Operating Power (W)	300 W	300 W

\*50 Hz models available on custom order.

\*\*Three-phase models available on custom order.

Specifications subject to change without notice.

**BKP™ and BKP-AC™ SERIES TROUBLESHOOTING CHECK LIST**

Company: _____ Phone: (____) _____ Fax: (____) _____ Job Name: _____ Model # : _____ Serial # : _____ Test performed by: _____ Date: _____	
--	--

Test		Dehumidification	Air Conditioning
<b>Air</b>	Return Air Flow	CFM	CFM
	Return Air Temperature	___ °F DB ___ °F WB	___ °F DB ___ °F WB
	Return Air Static Pressure (Negative)		in. WG
	Return Duct Size	" Depth	" Width
	Supply Air Temperatures	___ °F DB ___ °F WB	___ °F DB ___ °F WB
	Supply Duct Air Pressure (Positive)		In. WG
	Supply Duct Size	" Depth	" Width
	Condensate after 15 min (see <b>Note</b> below)		
<b>Refrigerant</b>	High Discharge Pressure / Sat. Temperature	___ psig ___ °F	___ psig ___ °F
	Liquid Line Temperature / Sight Glass	°F SG Clear? <input type="radio"/>	°F SG Clear? <input type="radio"/>
	Low Suction Pressure / Saturated Temperature	___ psig ___ °F	___ psig ___ °F
	Suction Line Temperature (@coil outlet)	°F	°F
	Suction Superheat	°F	°F
<b>Elec.</b>	Compressor ___ Volts / Amps at outdoor °F	___ Amps at ___ °F DB	___ Amps at ___ °F DB
	Indoor Blower <input type="radio"/> Lo <input type="radio"/> Med <input type="radio"/> Hi Volts/Amps	___ Volts	___ Amps
<b>BKP-AC</b>	Outdoor Fan _____ Volts / Amps		_____ Amps
	Outdoor Fan Pressure Switch set at		ON: _____ psig OFF: _____ psig
	Vapor Line Length / Size		_____ ft _____ "OD
	Liquid Line Length / Size		_____ ft _____ "OD

**Note:** To perform condensate flow test, run the unit for 15 minutes, then capture condensate for 5 minutes in a graduated container. Air side conditions must be measured during this time.  
 Is condensate TRAP properly installed?  Yes.  No.

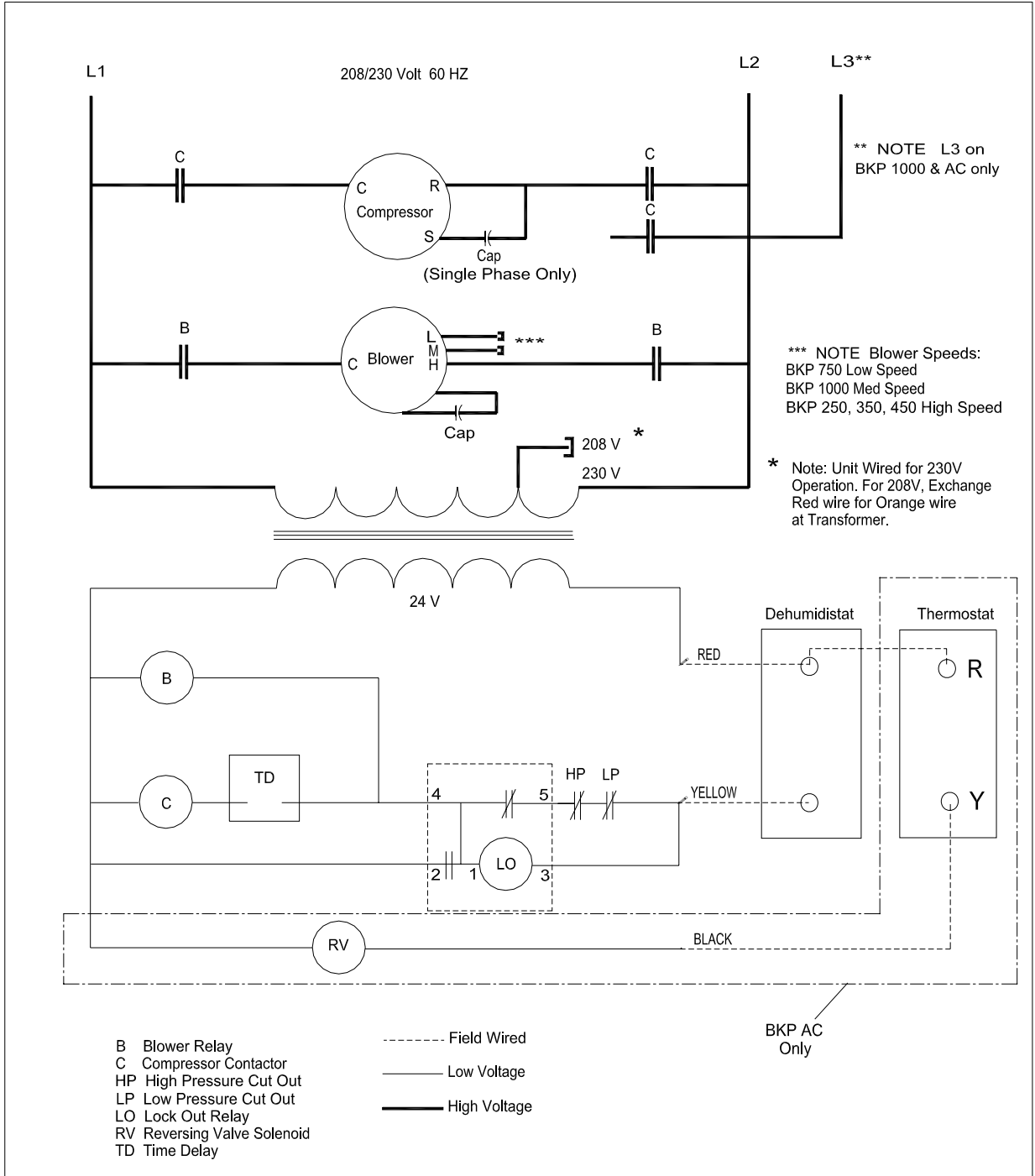

BKP 250, 450 and AC Wiring Schematic

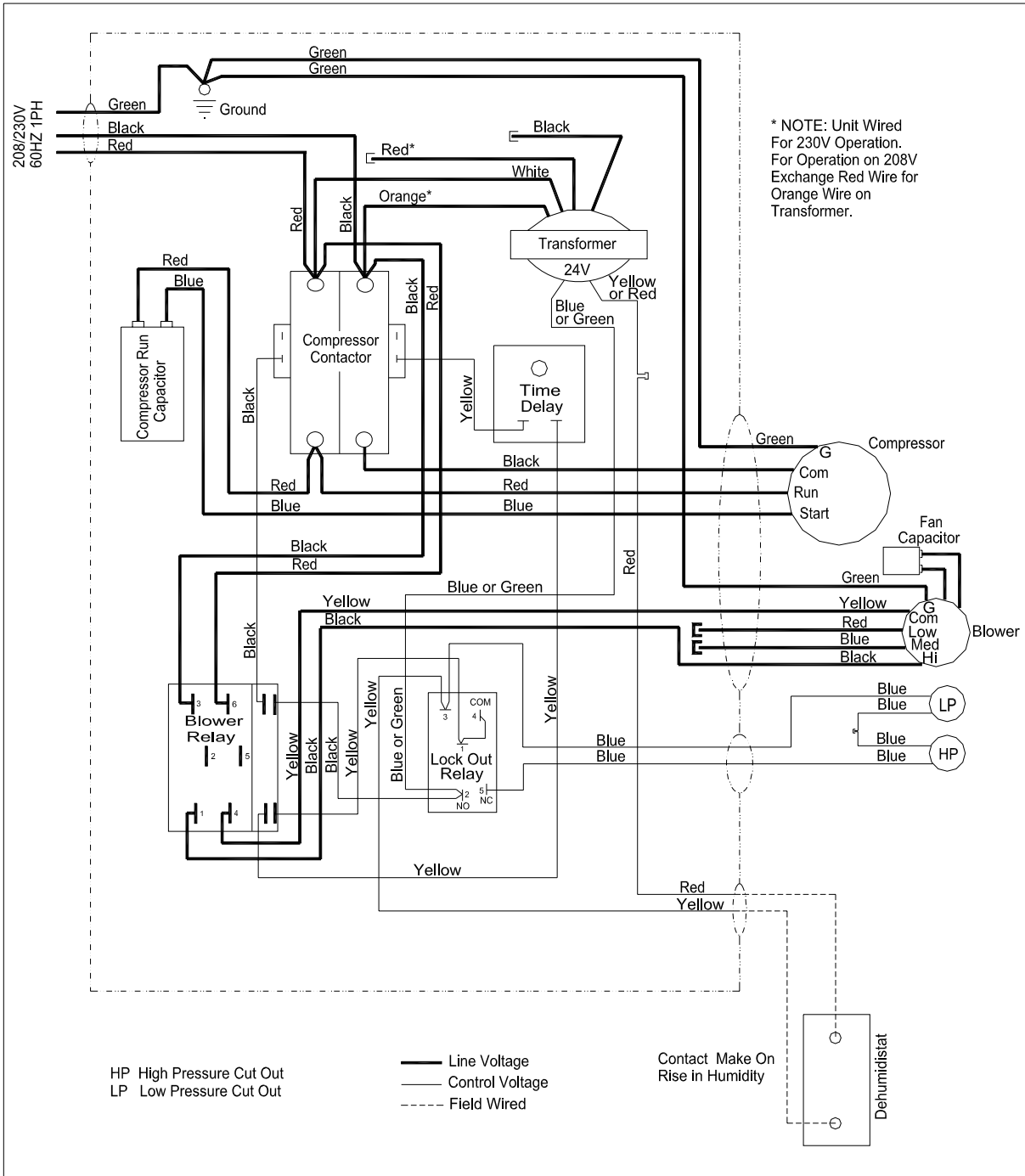

BKP 250, 450 Wiring Diagram

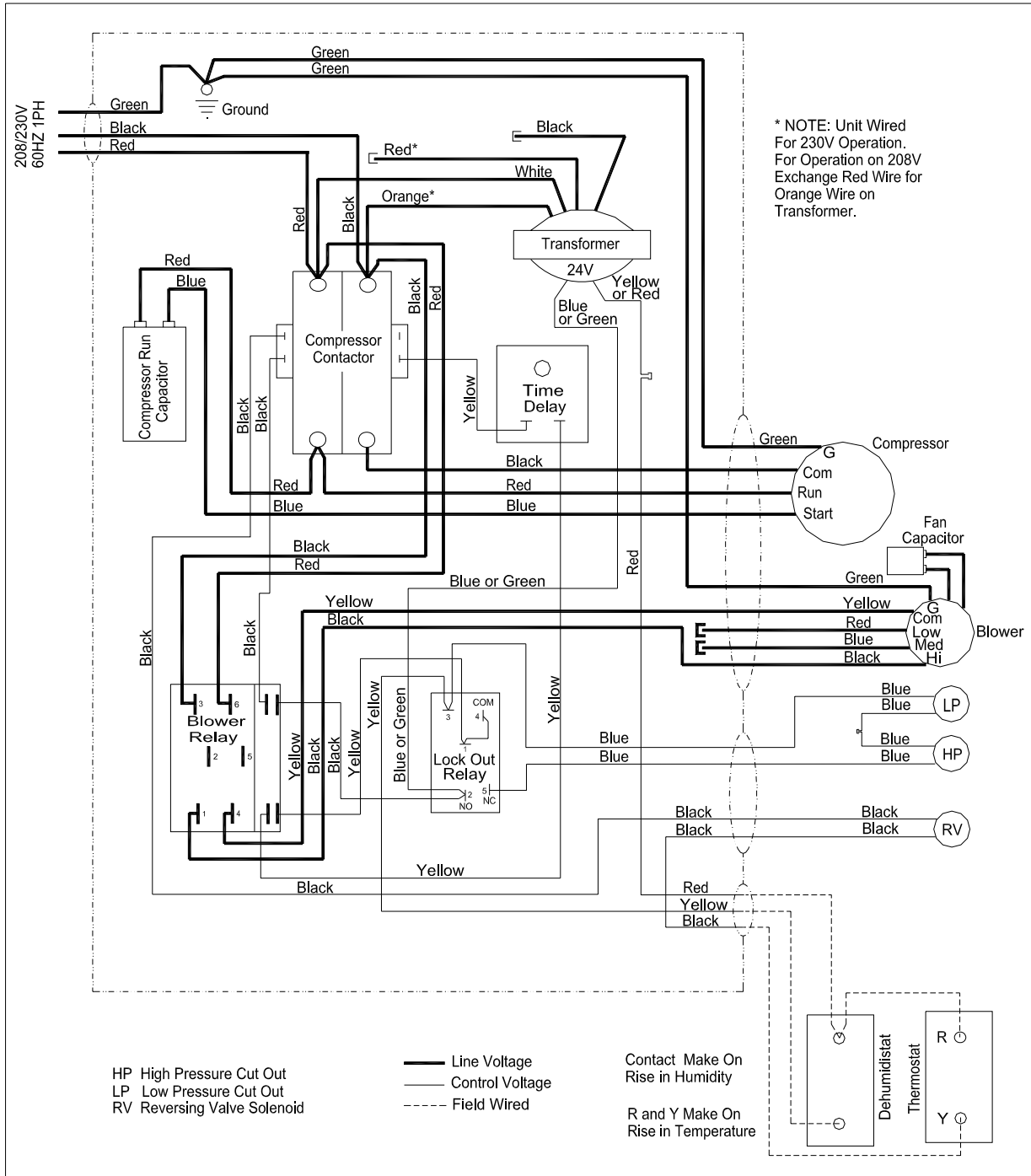

BKP 250AC, 450AC Wiring Diagram



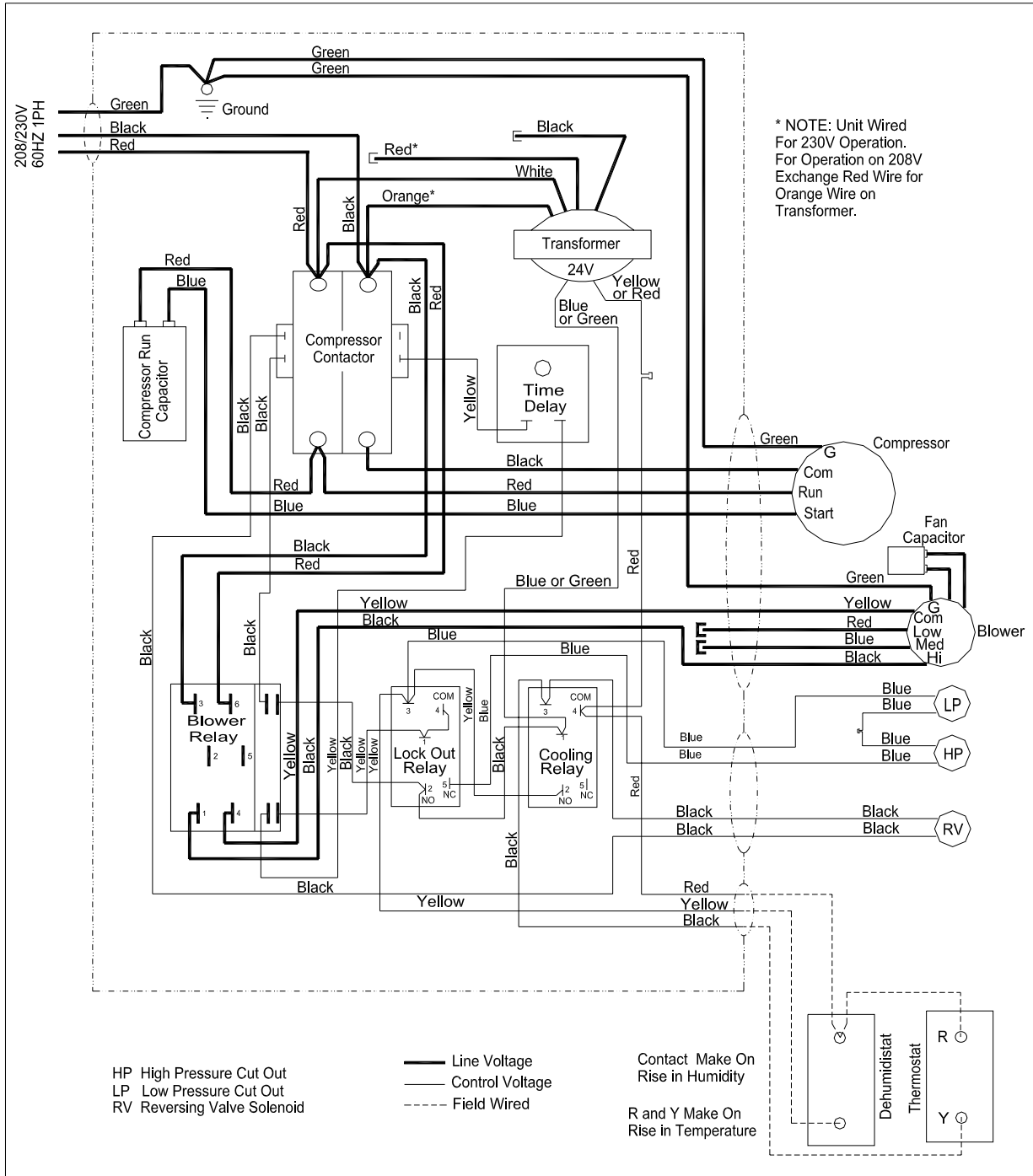

BKP 250AC, 450AC With Cooling Priority Wiring Diagram

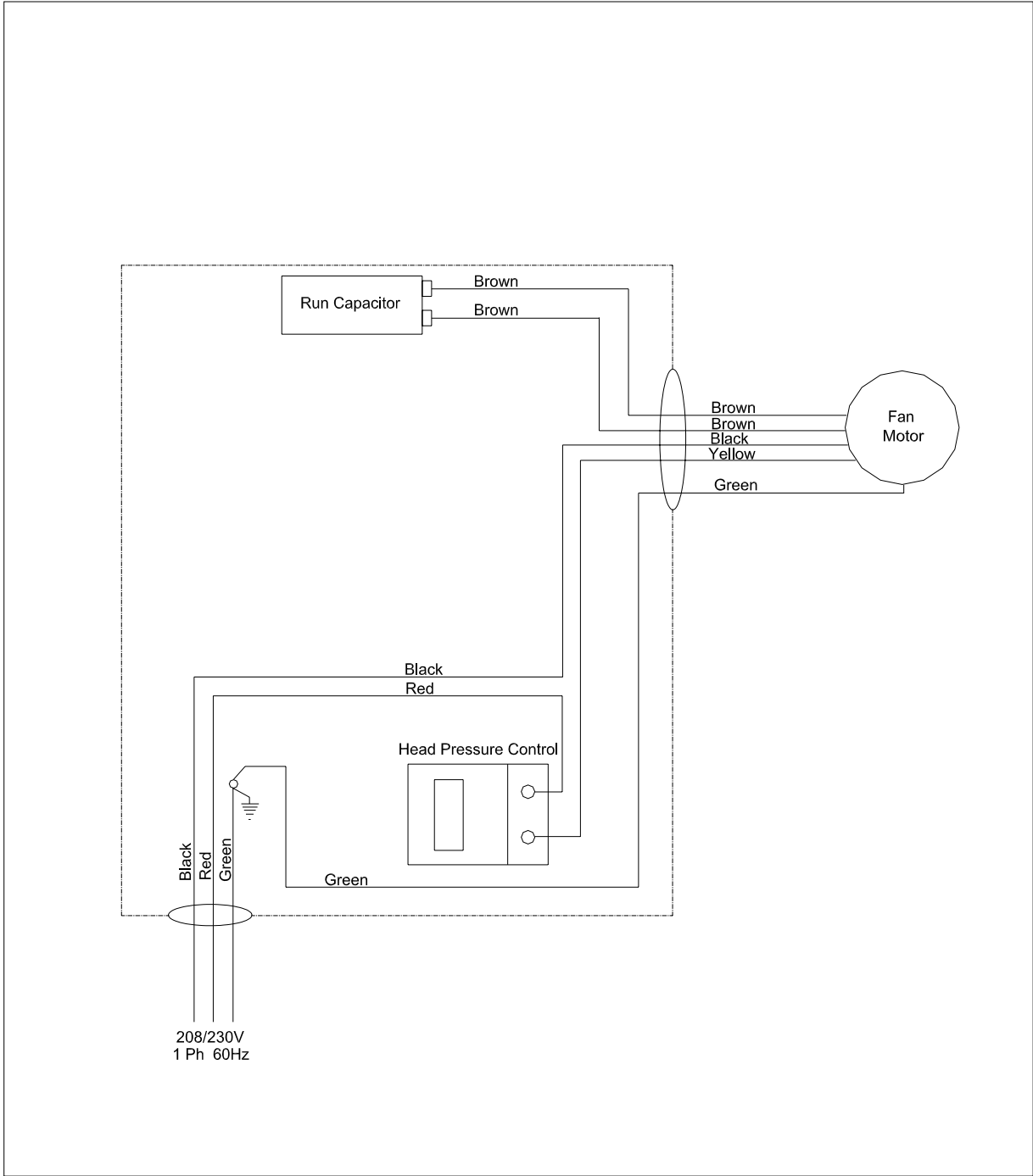

BKP 250AC, 450AC Remote Condenser Wiring Diagram

## 11. BKP™ TROUBLESHOOTING

Follow each applicable section in order from top to bottom.

Note 1 - Acceptable control voltage range 22 volts to 30 volts.

### 1) The unit does not start.

<i>Possible Cause</i>	<i>Solution</i>
No power to the unit.	Check the voltage to unit at the top of contactor.
Humidistat set above space humidity level.	Lower the humidistat setting.
If the unit locks out	Reset the BKP™ by turning the dehumidistat up and then down. then wait for time delay. If the BKP™ locks out again Follow Procedure #3 "Unit locks out before starting"
Check if the transformer has 24V. (see note 1)	If no, replace the transformer
Check for 24V at lockout terminals 3 & 2	If no, make sure the dehumidistat and field wiring are OK.
Check for 24V at lockout terminals 1 & 3.	If yes, Follow Procedure #2 "Unit locks out before starting"

### 2) Fan runs but compressor doesn't

<i>Possible Cause</i>	<i>Solution</i>
Check for 24v across time delay	If yes wait 5 minutes. If compressor does not start, replace the time delay
Check for 24v at the compressor contactor coil	If yes and the contactor does not pull in, then replace the compressor contactor If no check wiring
Check Voltage at bottom of compressor contactor	If no, Replace contactor.
Check for proper voltage at compressor terminals	If no, Repair wiring from contactor to compressor.
Compressor is hot	Compressor off on internal overload. Let it cool down.
Check capacitor	Replace if bad.
Check compressor ohms	Replace if bad.

### 3) Unit locks out before starting.

Turn power off to unit for this section. Put gauges on high and low refrigeration ports.

<i>Possible Cause</i>	<i>Solution</i>
If both gauges are below 40 psig, the unit has a refrigerant leak	Repair and recharge the unit.
Low pressure gauge below 40 psig and high pressure gauge at saturation pressure	Replace thermal expansion valve and filter dryer.
If Low pressure is above 40 psig, and high pressure is below 250 psig,	Remove wire from terminal 5 of lockout relay. Continue below.
check continuity from wire to terminal 3 of lockout relay.	If there is continuity, replace the lockout relay.
No continuity across low pressure cut out.	Replace low pressure cutout.
No continuity across high pressure cut out.	Replace high pressure cutout.
If there is continuity across all cut outs then the wire between cutouts is open.	Replace or repair the wire.

### 4) Unit runs a short time then locks out.

A cardboard cover should be made to replace the front cover. Use the front cover for a template. Make sure the cardboard lays against the diagonal drip rail on the coil. Any leakage of air around the coil will affect the pressure readings. Cut a small flap in the cover that can be opened and closed to observe the sight glass. Start unit and observe the refrigerant pressures. The low pressure cutout is 15 psig. The high pressure cutout is 350 psig. If the unit tries to shut down on the low pressure switch, try to observe the sight glass just before it shuts down.

*Do not run the unit with the cover(s) off.*

#### 4a) Unit shuts down on low pressure.

<i>Possible Cause</i>	<i>Solution</i>
Insure inlet air conditions are above 70°F and 45% humidity	Do not run if conditions are too low.
For BKP-AC™ units check that unit does not shift into cooling if outdoor conditions are less than 50°F.	Do not run in cooling if outdoor temperature is below 50°F. if necessary install outdoor thermostat to prevent cooling operation below 50°F.
If there are bubbles in sight glass just before shut down, the unit may have a refrigerant leak.	Leak check, Recover refrigerant and repair. Replace filter dryer. Evacuate and weigh in charge.
If there are no bubbles in sight glass just before shut down,	Replace thermal expansion valve and filter dryer.

**4b) Unit shuts down on high pressure.**

<i>Possible Cause</i>	<i>Solution</i>
Check for proper airflow.	Replace filter, clean coil, duct and blower.
If air flow is low, check that the coil is not icing up.	Let ice melt and check for proper operation of the hot gas bypass
For BKP-AC™, the outdoor fan does not come on at 240 psig in cooling mode because there is no power to outdoor condenser.	Restore the power.
Pressure switch operation does not work.	Replace the pressure switch.
Fan motor not running.	Repair wiring to the motor and/or replace the fan motor.
If pressure is still high, unit has probably been overcharged. NOTE: Proper charge cannot always be determined by refrigerant pressures, and the sight glass can show bubbles under normal conditions.	Recover all refrigerant and weigh in proper charge.

**5) Unit shuts down occasionally.**

Follow the procedure under (4) "unit runs a short time then locks out". If unit shuts down, follow the outlined procedure. An occasional shut down can be a very difficult problem to diagnose. It usually involves some trial and error and multiple trips back to solve. If everything looks normal while the machine is running, consider whether there could be any environmental changes taking place during the day. Such as the air conditioning or heating being shut down at night while the BKP™ runs continuously. If it is a BKP-AC™, the unit could be tripping on cold nights when it shifts to the outdoor condenser. These units should be prevented from running in the cooling mode if the outdoor temperature is below 50°F.

Small trip indicators are available from local AC supply houses to help in diagnosis. These are attached across each safety cut out and will tell you which control is shutting the system down. This will narrow down the possibilities. Do not permanently bypass any safety control unless directed by the factory.

**6) BKP™ runs but does not dehumidify.**

Follow the procedure in (4) "unit runs a short time then locks out" to observe sight glass while running the BKP™. Using thermometers and hygrometers, take the dry bulb temperature and relative humidity readings at the air inlet to the BKP™.

<i>Possible Cause</i>	<i>Solution</i>
High and low pressure gauges did not move when the unit comes on.	Check compressor wiring, and capacitor. If compressor is hot, allow to cool. OHM compressor to determine winding condition. Replace compressor
If the compressor runs, but low pressure reads too high and high pressure reads too low.	Check if the hot gas bypass is leaking by. Check if the Reversing valve is leaking by. If both of these are OK, replace compressor.
If the compressor runs, but both low and high pressure reads low	Check if the evaporator coil is frosted up. If frost is present, allow the frost to melt completely. Check hot gas bypass
If pressures are still low, and there are bubbles in the sight glass, the unit may have a refrigerant leak.	Check for leak, recover refrigerant, repair leak, replace filter dryer, evacuate and weigh in proper charge.
If pressures are still low and there are no bubbles in sigh glass.	Replace thermal valve and filter dryer.
If high press reads high and low pressure is ok or high.	Check airflow through the unit. If it is low, check filter and ductwork. External static should not exceed 0.5" Check that air inlet temperatures are not too hot or too humid.
For AC units, if a hissing noise can be herd from the reversing valve, feel the check valve on the small tube from the center port.	If the check valve is hot while running then the reversing valve is leaking. Shift the unit from heating to cooling several times and then retest. If it is still hot, replace the reversing valve.
If no problems are found, unit may be overcharged.	Recover refrigerant. Evacuate and weigh in proper charge.

**For BKP-AC™**

**7) BKP-AC™ runs in either dehumidification or cooling mode only but does not change mode (reversing valve does not shift).**

Remove the cover from the thermostat. Turn the temperature setting all the way up then all the way down. Observe the mercury in the glass bulb. If the mercury does not move from one end of the bulb to the other, replace the thermostat. If the bulb does not "rock over" at the current temperature, replace the thermostat.

Remove either wire from the time delay to keep the compressor from starting. With the thermostat all the way down, check for 24 V at the reversing valve coil. Do not run the BKP™ compressor without a cover.	If yes, then the reversing valve coil or the valve itself is bad. If no, check the wiring to the thermostat and to the BKP
If you have voltage to the reversing valve coil, have someone turn the thermostat up and down as you listen for a definite "click" in the reversing valve.	If The valve clicks but does not shift, replace the reversing valve If the valve does not click replace the solenoid coil.

## **BKP™ and BKPool™ Series Packaged Dehumidifier Twelve-Month Limited Warranty**

---

Subject to the following conditions, Heat Pipe Technology, Inc. (HPT), warrants this product to be free from defects in material and workmanship for a period of TWELVE MONTHS from the date of installation, not to exceed 90 days from date of shipment. This warranty is in lieu of all other warrants not expressly set forth herein, whether expressed or implied by operation of law or otherwise. In the event this product fails under normal use and service within the applicable period, HPT will correct, repair or, at its sole discretion, replace the defective product or refund the purchase price of products which are returned freight prepaid to HPT for inspection, when accompanied by proof of purchase and written claims of defect, and which upon inspection by HPT, do comply with the terms of this warranty.

This warranty applies to the first retail buyer and extends to any subsequent owners of the systems.

### **Additional Three-Year Limited Warranty On Compressor (Packaged Equipment Only)**

Additionally, HPT warrants the COMPRESSOR to perform under normal use and conditions for a period of THREE YEARS from the date of completion of installation, not to exceed 90 days from date of shipment, when installed in accordance with factory instructions and recommendations. In the event the compressor malfunctions or fails to perform during this warranty period, HPT will repair or, at its option, replace the compressor at the pro-rated schedule of cost shown below:

Percentage of repair or replacement cost paid by Heat Pipe Technology, Inc.

Month of Claim	Percentage
1 - 12	100%
13 - 24	66%
25 - 36	33%

The cost of replacement parts or components shall be determined by the price schedule in effect at the time of submission of warranty claim.

Repair or replacement parts will be furnished F.O.B. factory in all cases.

If HPT elects to replace or provide a refund, the defective product must be returned to HPT free and clear of liens or other encumbrances.

### **Limitations on Liability**

- A. **This warranty does not cover and no warranty is made with respect to:**
- B. Failures not reported to HPT within the period specified above;
- C. Failures or damage due to misapplication, misuse, abuse, improper storage or handling, abnormal conditions of temperature, water, dirt, corrosive substances or other contaminants;
- D. Products which have been repaired with parts or materials not furnished or approved by HPT or by its authorized dealers or representatives, or products which have been in any way tampered with or altered; and
- E. Products damaged in shipment or storage or otherwise without fault of HPT.
- F. Failure of the product resulting from modifications to the product or due to unreasonable use including failure to provide reasonable and necessary maintenance. Failure due to corrosion on models not corrosion protected. Damage to the product caused by improper power supply voltage, accident, fire, floods, or acts of God. **WARRANTOR IS NOT RESPONSIBLE FOR CONSEQUENTIAL DAMAGES.**

HPT total responsibility for any claims, damages, losses or liabilities related to the product covered hereunder shall not exceed the purchase price of such product. In no event shall HPT be liable for any special, indirect, incidental or consequential damages of any character, including but not limited to loss of use of productive facilities or equipment, lost profits, property damage, transportation, installation or removal, lost production, or personal injury whether suffered by Purchaser or any third party. HPT disclaims all liability for any and all costs, claims, demands, charges, expenses or other damages, either direct or indirect, incident to personal injury or property damage arising out of any cause of action based on strict liability.

Some states do not allow the exclusion or limitation of incidental or consequential damages or limitations on how long an implied warranty lasts, so the exclusion or limitation above of consequential damages or the limitation of time above on implied warranties may not apply to you.

This warranty gives you specific legal rights and you may have other rights which may vary from state to state.

# Warranty Registration

---

---

To insure your warranty protection, please fill in the Warranty Registration form and mail or fax it to:

**Heat Pipe Technology, Inc.**  
4340 NE 49<sup>th</sup> Avenue, Gainesville, FL 32609  
Fax: (352) 367-1688

<b>WARRANTY REGISTRATION FORM</b>	
Customer Name:	
Customer Address:	
Phone: (     )     -	Fax: (     )     -
Please Check One: <input type="checkbox"/> Homeowner <input type="checkbox"/> Dealer	
Model No:	Serial No:
Type of Product:	
Date of Installation:	Dealer/Installer:
Name & Address of Dealer/Company You Purchased from	
Name:	
Address:	
Customer Signature:	